

# - IMPORTANTE -

## LEER ANTES DE INSTALAR EL SISTEMA

### 1. Condiciones Medioambientales para la instalación:

- a. Montaje de posición de detector EAS:
- b. El detector EAS no puede ser colocado a una distancia inferior a 1.5m de cualquier objeto metálico incluyendo puertas, los refuerzos metálicos de la pared, estanterías metálicas, Carritos de compras, etc. También no está permitido montar este detector a una distancia inferior a 2m cerca de cajones de dinero, dispositivos ID para tarjetas de crédito, teléfonos, ordenadores, cables de datos, lámparas de neón, acondicionadores de aire, calentadores, etc.
- c. Para asegurar la confiabilidad de operación del sistema EAS, al principio es necesario descubrir las fuentes de interferencia y poner el sistema lo más lejos posible de estas fuentes, si es que ellas no pueden ser removidas o reubicadas. Generalmente hay dos clases de interferencia: la primera es activa, como lo son las chispas eléctricas debidas al contacto impropio de componentes, motores y/o interferencias causadas por los ruidos serios de fuente de alimentación o reactancias y la segunda es pasiva como lo son rollos de conductores (cables) de máquinas de POS, cajones de de dinero, las diferentes señales de cables eléctricos enrollados de impresoras, etcétera.

### 2. Limitaciones:

- a. Puede haber alguna limitación en el empleo del sistema EAS, ya que el detector EAS Trabaja sobre el principio de armonía electrónica y el escudo metálico pueden hacerse inválidos. Los usuarios deberían ser conscientes de la situación que algunos bienes como la leche en polvo, el chocolate, etc. El paquete de película metálica no puede ser protegido con la etiqueta EAS adherida directamente. En tal caso, se deberán adoptar medidas para que el sistema EAS funcione, por ejemplo cajas protectoras.

### 3. Montaje:

- a. Hacer un surco sobre el lugar definido para pasar los cables entre el transmisor y el receptor.
- b. Colocar en el surco el tubo metálico por el cual se pasará el cable mallado bipolar.
- c. La base será fijada con los tornillos después de taladrar y colocar los tarugos.
- d. Note que no debería haber ningún objeto metálico alrededor de la unidad principal.
- e. Si el cable de alimentación baja desde el techo, debe estar alejado por lo menos 2m del detector y la malla de aislación conectada con tierra para evitar cualquier interferencia, un tubo de acero puede ser aplicado al cable de alimentación para proteger al sistema en caso de ser necesario.
- f. Para el cable de alimentación se recomienda una línea separada. No recomiendan un enchufe pobre porque el contacto impropio del mismo puede causar la chispa de alta frecuencia que termina en el trabajo inestable de antena y hasta detecciones falsas.
- g. Los Desactivadores y las antenas EAS trabajan en una misma gama de frecuencia, por lo cual ellos se interferirán el uno con el otro cuando estén puestos muy cerca. Por lo tanto, la distancia entre ellos debería ser más de 1 metro. El Desactivador no deberá ser puesto sobre una superficie metálica directamente.

### 4. La fuente de alimentación:

- a. La longitud máxima del cable sin el filtro no debería exceder 5 metros.

- b. Si tiene que usar el cable más largo para la fuente de energía debería agregar un filtro por aprox. 4 metros.
- c. La Fuente de alimentación del detector EAS entrega 10A de dos polos y requiere una alimentación de corriente alterna de 220V independiente (separada) para evitar la interferencia con otro dispositivo.
- d. El cable de la fuente de alimentación debería alejando del cable telefónico y de cualquier cable de otros equipos electrónicos.
- e. La máxima longitud del cable desde la fuente de alimentación hasta el sistema de Antenas EAS no debe superar los 10m.
- f. La salida de poder adicional P6 de corriente continua con filtro del transmisor también puede ser usada como un filtro.
- g. Etiquetas y Hard Tags no deberían alrededor del cable de alimentación.
- h. Se recomienda colocar el cable de alimentación dentro de un tubo metálico para evitar la interferencia.
- í. Si el ambiente tiene interferencia fuerte use en el cable de la fuente de alimentación y en los cables de conexión cable mallado con 2 polos  $\times$  0.5mm<sup>2</sup> por cable, y la malla no tiene que estar conectada con el sistema.

### 5. Cable de Sincronización:

- a. Si dos o más antenas TX (Transmisores) son instaladas a una distancia inferior a 15m, las antenas TX deberían estar sincronizadas. Se deben usar cables de HF para la Sincronización. El diagrama siguiente es de sincronización de 3 etapas (1 Maestro y dos Esclavos):

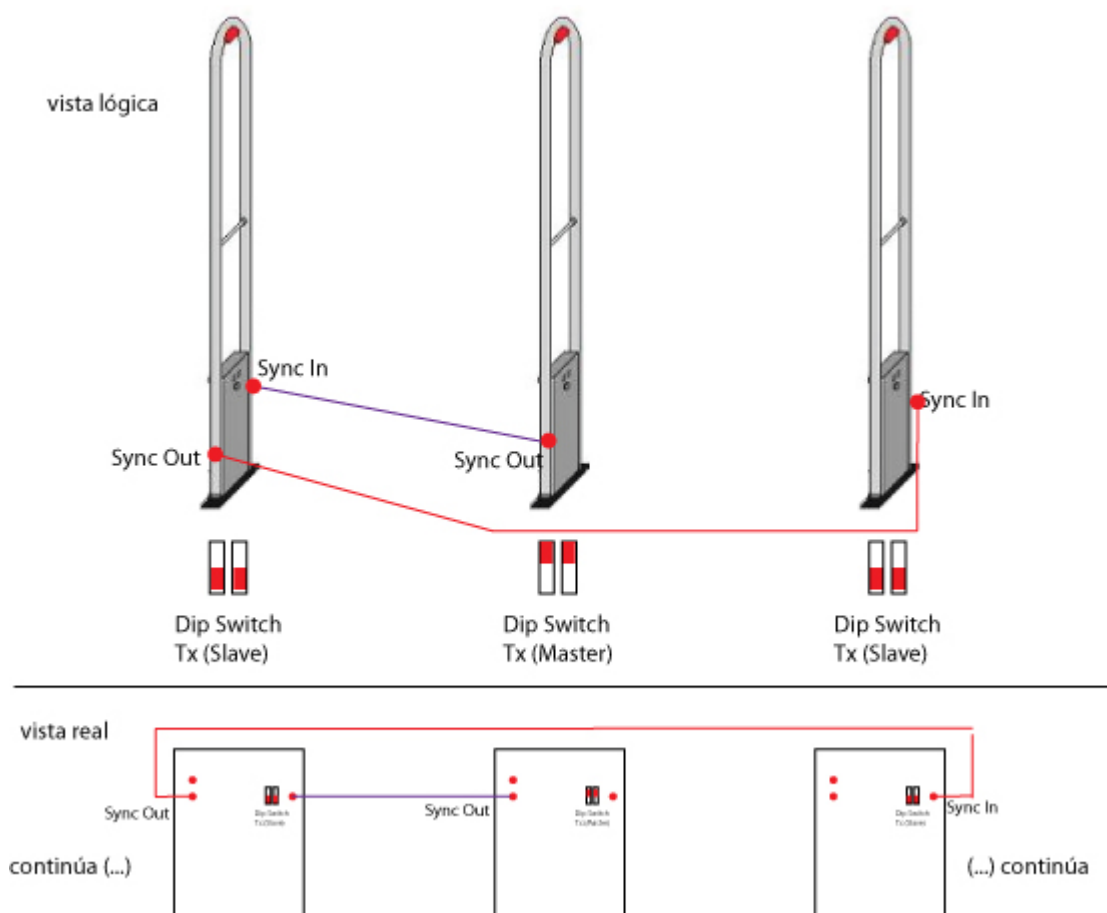

- b. Tener en cuenta que cada TX (Maestro o Esclavo) puede estar conectado a uno o dos RX.

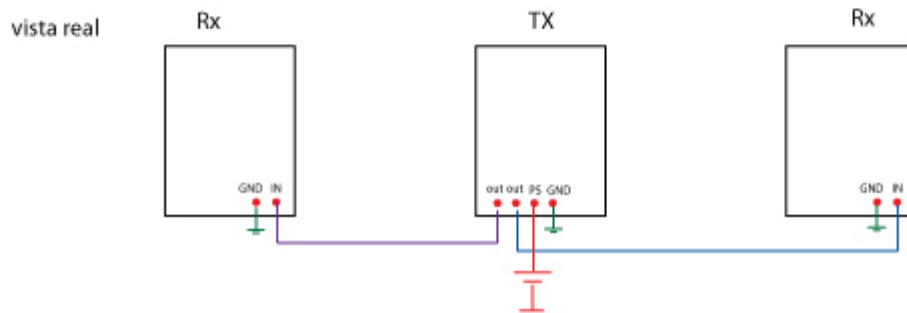
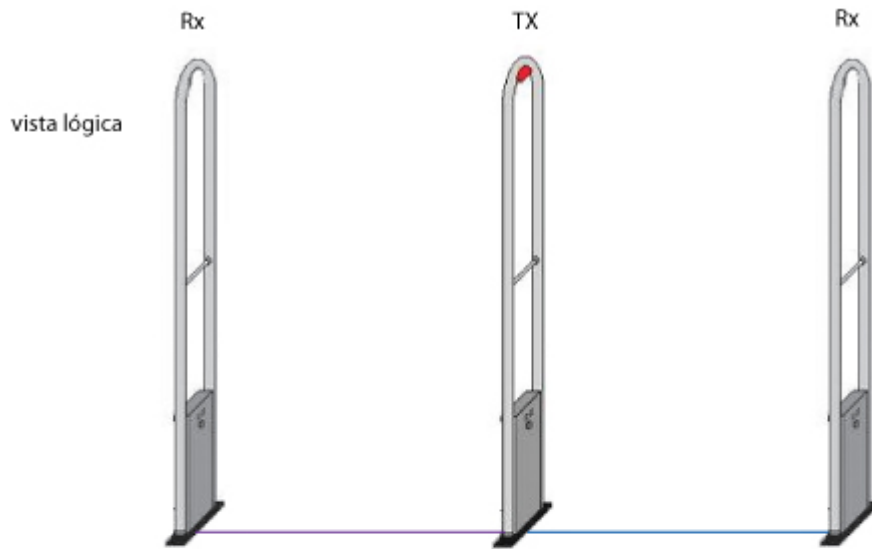

- c. NOTA: El cable de sincronización normalmente requiere de la utilización de un anillo de ferrita para la reducción de resonancias indeseables. La sincronización por cable sólo puede ser puesta en práctica con el ambiente libre de interferencias y la instalación debería ser manejada por técnicos experimentados.
- d. Asegúrese que el cable de sincronización sea siempre conectado al terminal correspondiente, de la Sincronización IN a la Sincronización OUT, para evitar errores de fase (Ej: usando diferentes colores).
- e. Los dips Switch ubicados en el centro del Mother board son los que nos permiten definir al TX Master o TX esclavo, siendo la posición 1-ON (default) la que define al Maestro y la posición ON-1 la que define al Esclavo.
- f. Synchronization output: P3 (SYNC OUT), P4 (SYNC OUT)
- g. Synchronization input: P2 (SYNC IN)
- h. Calibrar cada conjunto de Transmisor (TX) y Receptor (RX) por separado antes de conectar el cable de Sincronismo. Una vez realizado esto conectar los cables de sincronismo correspondientes entre TX Maestro y TX Esclavo y realizar el ajuste fino.

# **DYN-DPA102 EAS System**

Specification  
Installation  
and  
EAS System Tuning  
Manual

## I. Principales Parámetros Técnicos

### Transmisor:

Power supply	DC 24V
DC source	<300mA
Safeguard	250V, 1A, fuse
Center frequency	8.1MHZ
Scanning frequency bias	$\pm 700\text{KHZ}$
Scan rate	180HZ $\pm 1\text{HZ}$

### Receptor:

Power supply	DC 24V
DC source	
in guard status	<300mA
in alarm status	<400mA
sensitivity	5 $\mu$ A
Safeguard	250V, 1A, fuse
radio-frequency bandwidth	7.5MHZ $\sim$ 8.5MHZ

## II. Environmental Conditions

1. Mounting position of EAS detector: EAS detector cannot be set up in the distance of 0.5m from a metal door or 1 m from any metal objects inducing the metal wall reinforcements, goods shelves, metal showcases, hand purchasing carts, etc. It is also not allowed to mount this detector in 2m nearby the money machines, ID devices for credit cards, telephones, computers, data cables, neon lamps, air conditioners, heaters, etc.
2. To ensure the EAS operation reliability, at first it is necessary to detect the interference sources and set the system far away from these sources if they are difficult to be removed. Generally, there are two kinds of interference: the first is active in nature such as the various electric sparks, motors, blowers and fire due to improper contact, or interferences caused by serious noises of power source; the second is passive in nature such as the conduct rolls, pos machine on money acceptance desk, different signal lines of printer power cords in roll and so on.
3. The power case of EAS detector uses 10A two poles and a grounding plug. A separate power source AC 220V is required to avoid the interference with the other appliance. The power wire should be kept away from telephone wire, cable wire and wires for other electronical equipments. Soft labels and hard tags should not be kept around the power wire. The power socket must be conformed to the standard 10A double-pole socket with a grounding plug. Moreover, the power wire should be put in the metal tube separately for avoiding the interference.
4. There may be some limitation in use of EAS, since RF detector works on the principle of electronic harmony and the metal shield may become invalid. Users should be aware of the situation that some goods such as

milk powder, chocolate, etc. In metal or metal film package may be not protected with the EAS tag adhered directly. In such a case, the dedicated binder tape or protective box is adopted for protection.

### III. Mounting mode

#### 1. Installation

- 1) Make a groove on the definite place to bury the power cords. The rack base is fixed with the steel tight-fitting screws after drilling the holes. Note that there should not be any carts or metal objects around the main unit. If the power wire comes in through the ceiling, it must be in 2m apart from the detector and the insulation layer grounded to avoid any interference, a steel tube can be applied to the power wire for screening if necessary. For power wire, the separate opening is required with good connection. A poor socket is not recommended because the improper contact may cause high-frequency spark resulting in unstable work of antenna and even misdetecting.
- 2) Deactivator and antenna work at a same frequency range. they will interfere each other when they are put too close. therefore, the distance between them should be more than 1 meter. deactivator pad should not be put on a metal surface directly.

#### 2. Connection

- 1) For using single set, connected to power supply only. The power supply must meet specific requirements of safety, electromagnetic compatibility and fluctuation coefficient of the system and so on.

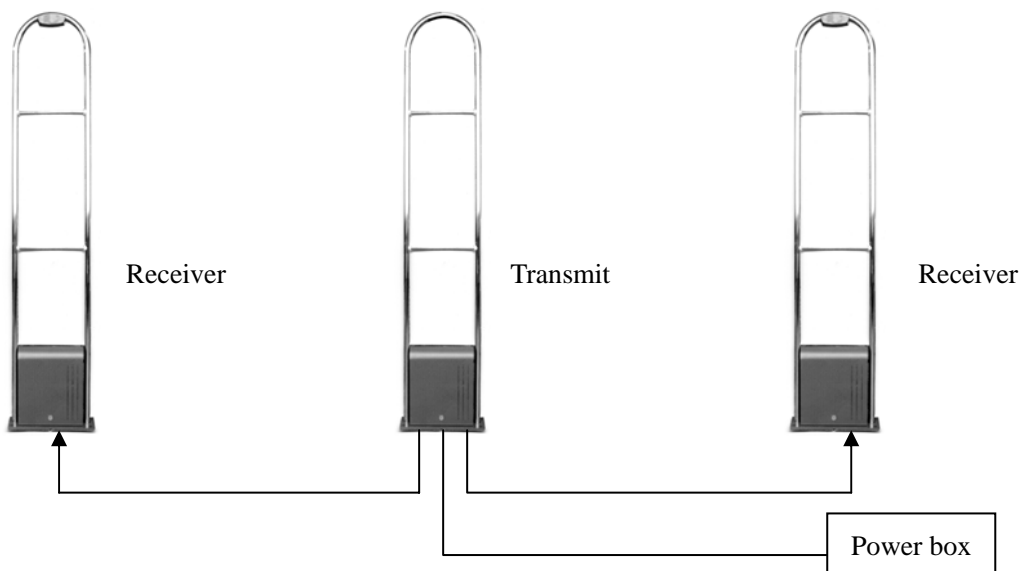

Transmitter board

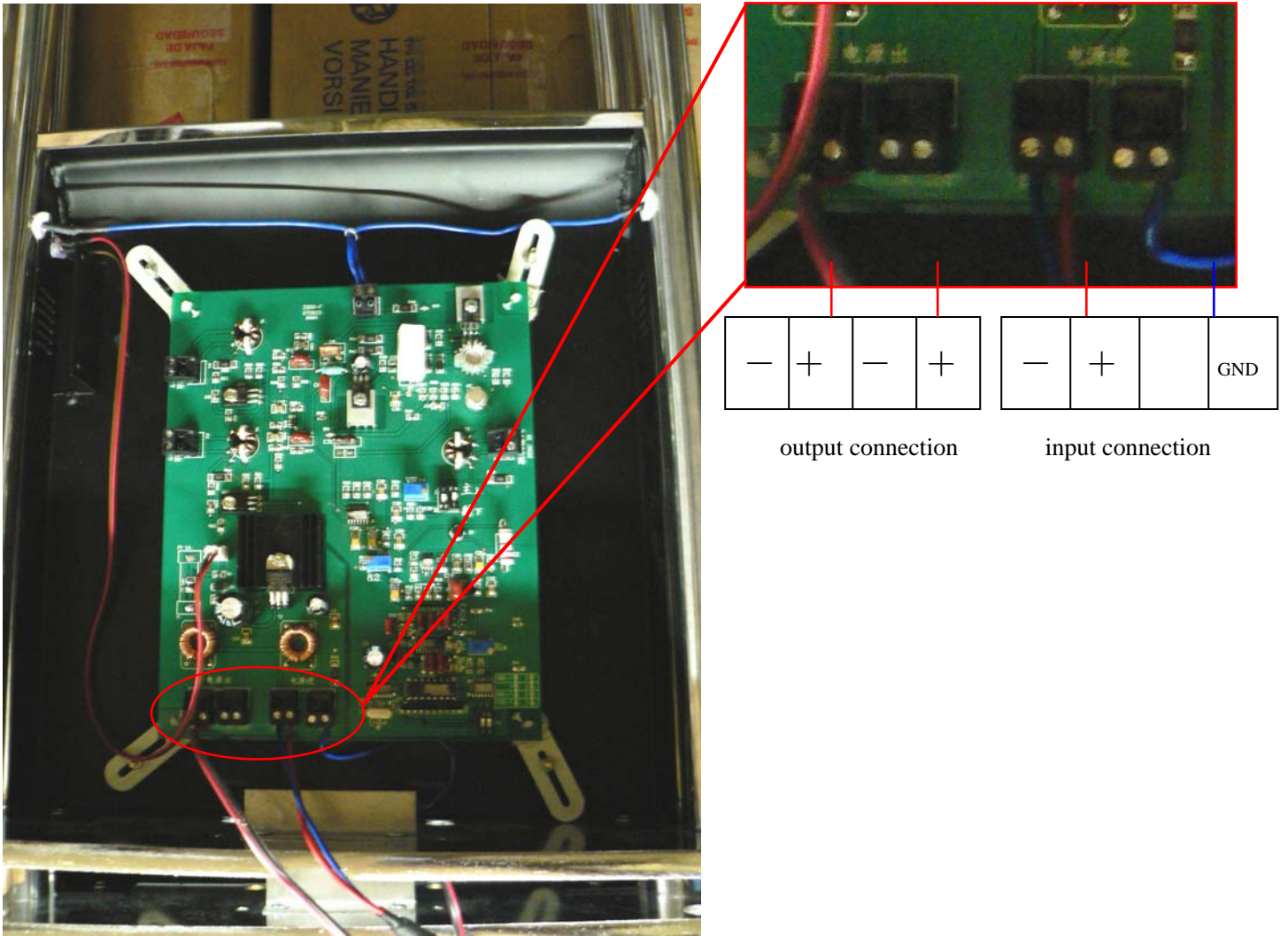

\* "GND" refers to the earth wire on transmitter.

Receiver board

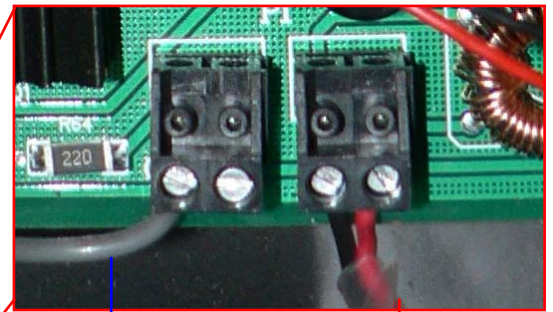
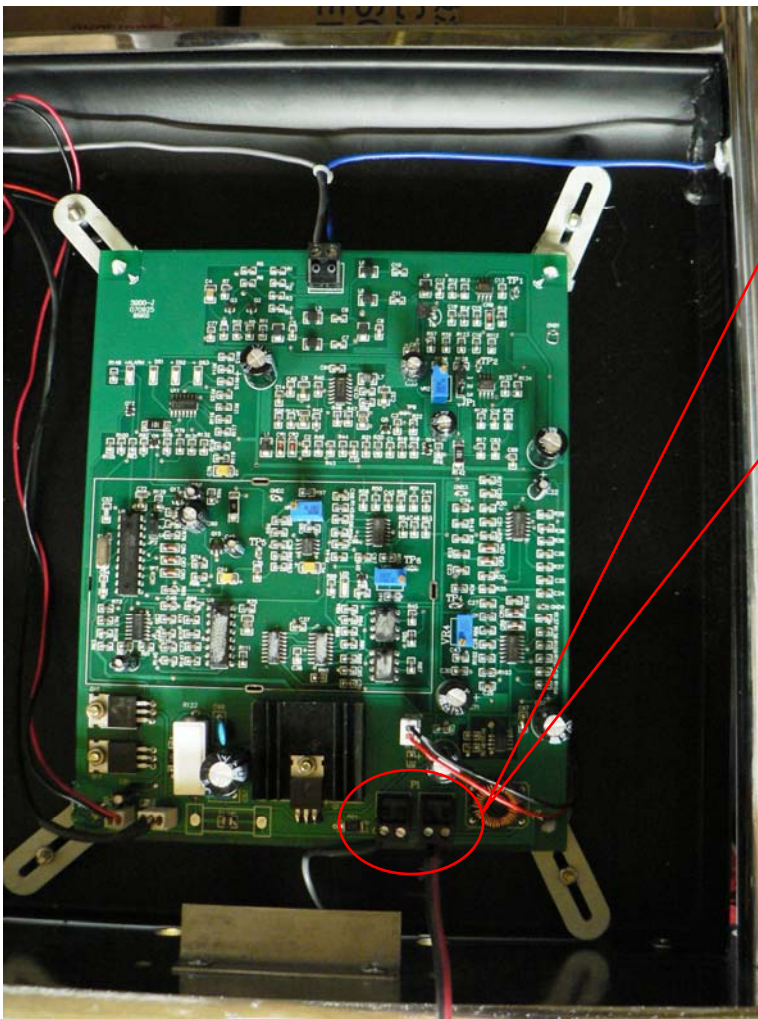

input connection (a)

(a) The cable comes from the output connection of the transmitter.

(\*)“GND” refers to the earth wire on receiver.

## IV. Adjust

### 1. Receiver Tuning

- 1) On the scene, when the DS1 is a little bit flicker and DS2, DS3 are dark, it shows that there is a slight interference and the system can work stable, but the rate of detection drops 30%. If the DS1 is always shining, it indicates the environment is not good and the system is interfered seriously, so it needs to find the disturbing sources and eliminate or change the installing site.

LED		indicate note
green light	DS3	strong interfere or alarm signal
green light	DS2	close alarm or touch alarm
green light	DS1	have light interfere

red light alarm	alarm
-----------------	-------

- 2) The system has advanced automatic control circuitry. It can be adjusted to different environments by tuning the sensitivity of the receiver only. Tune VR4 clockwise for higher sensitivity. The green LED DS1, DS2 and DS3 may twinkle when you tune VR4. LED is the indicator light during adjustment which does not or seldom flicker when it is still. VR4 controls sensitivity as well as the static state which is reflected by the indicator light. The best tuning result is no twinkling from DS1, DS2 and DS3.
- 3) Setup for sound alarm and light alarm: Set JP2 on 1&2 (factory state). The sound alarm and light alarm will happen simultaneously and last for 2 seconds. Set JP2 on 2&3. The sound alarm and light alarm will happen simultaneously and last for 2 seconds together. The sound will stop then while the light will last another 3 seconds.
- 4) Installation distance and label & hard tag match: Installation distance is on the 1 meter to 1.2 meter, both OK for label and hard tag; setup JP1 on 1&2. Installation distance is on the 1.2 meter to 1.6 meter, recommendation for using hard tag; setup JP1 on 2&3.
- 5) If adjustment of VR4 has little effect against the disturbance outside, please adjust VR6 (in the eyelet of metal box on the receiver) anticlockwise to improve the anti-jamming ability of the antennas and adjust VR4 clockwise to improve the sensitivity of the system.
- 6) Main test points:
  - A. TP1—Radio Frequency (RF) receiving amplitude Installation distance is less than 1.2 meter, setup JP2 on 1&2 (automatic state) , TP1 Radio Frequency (RF) receiving amplitude  $500\pm 50\text{mVp-p}$ ; Installation distance is more than 1.2 meter, less than 1.6 meter, setup JP1 on 2&3 (manual state) , TP1 Radio Frequency (RF) receiving amplitude  $300\pm 50\text{mVp-p}$ ; adjustment by VR2.
  - B. TP4—static noise (A) Amplitude  $400\pm 50\text{mVp-p}$ ; adjustment by VR4.
  - C. TP5—static noise (B) Amplitude  $100\pm 10\text{mVp-p}$ .

## 2. Transmitter Tuning

- 1) There are four modulation signals on the transmitter namely 150, 160, 170 and 180Hz to avoid problems caused by multi-connection of EAS antennas. The choice of different modulation signals can prevent inter-disturbance between EAS antennas. The priority modulation signal is 180Hz and the factory default setup is 180Hz.
- 2) Frequency width adjustment This adjustment is relevant to the width of the gate. Connect the probe of oscilloscope to TP7. VR23 can change the output of RF amplitude. TP7 is the sine wave of 40-70Vp-p.
- 3) Central frequency adjustment Connect the probe of frequency instrument to TP6 and TP8. Adjust VR15 to  $8.2\pm 0.05\text{MHz}$ .
- 4) If several transmitters are working not synchronously, please choose different sweep frequencies. During the installation, if it is difficult to connect 2 or more transmitters properly, make each antenna working under a different modulation frequency such as

150,160,170 or 180Hz to avoid inter-disturbance. Please install the system according to the following principle in the actual situation:

For the antennas which are not connected with each other, the distance in between should be 10 meters above. Please connect the antenna synchronously as possible as you can, it will make the system work stable.

5) Test points of transmitter:

R23: Frequency width adjustment

R15: Frequency adjustment (8.2MHz)

R14: Transmitting power adjustment (sweeping scope)

## V. Easy methods for trouble shooting

Troubles	Items to be checked	Solution
The power lamp does not light up.	(1) Check that the power switch is turned on; (2) Confirm that the plug is connected properly; (3) Make sure the fuse is not burned and the lamp works.	(1) Turn on the power switch; (2) Firmly connect the plug and socket; (3) Replace the fuse; (4) Replace the lamp.
The indicator doesn't light up when the alarm sound is on.	(1) Make sure the alarm indicator works; (2) Verify that the connection is alright.	(1) Replace the alarm indicator; (2) Check the connections.
The alarm sound doesn't come up when the indicator is on.	(1) Make sure the buzzer works; (2) Verify that the connection is OK	(1) Replace the buzzer; (2) Check the connections.
False alarm or self-alarm with the indicator light on	Check the following aspects: (1) Whether the voltage of the system power supply is 220V or not; (2) Whether there are tags around the antenna; (3) Whether there are tags around the power wire; (4) Whether the disturbance is too much; (5) Whether there are any other electrical equipment is also connected to the special wire for the antenna; (6) Whether there are some electrical equipments or big metal articles(shelf, bag cabinet) within 2	(1) Add a manostat or use UPS if the voltage is not stable; (2) Remove the tags all around; (3) Eliminate disturbance source and tune VR6 if disturbance elimination is impossible; (4) Replace the electronic board; (5) Remove the other equipment connected to the wire for the antenna; (6) Remove all the other electrical equipment and metal articles(shelf, bag cabinet) in 2 meters around the antenna; (7) Remove the web wires,

	<p>meters around the antenna;</p> <p>(7) Whether there are web wires, super wires for 220V&amp;380V, telephone lines and sound box wires within 2 meters around the antenna;</p> <p>(8) Whether the deactivator is sharing the same power supply with the antenna and whether they are too near to each other.</p>	<p>telephone lines, super wires and so on in 2 meters around the antenna;</p> <p>(8) Use separate power supplies for deactivator and the antennas and make sure the distance between two power supplies is no less than 2 meters.</p>
No alarm	<p>Check the status of the antenna:</p> <p>(1) Whether the green light on the receiver is twinkling and whether it responds when the tag approaches;</p> <p>(2) Whether all the slip stitches are connected properly;</p> <p>(3) Whether the power supply works well;</p> <p>(4) Whether bnc connector plugs on the electronic board and all the wires are connected properly.</p> <p>(5) Whether there are some electrical equipments or big metal articles within 2 meters around the antenna;</p>	<p>(1) Tune it again according to the tuning manual to improve the sensitivity;</p> <p>(2) Connect the slip stitch properly;</p> <p>(3) Add a manostat or use UPS if the voltage is not stable; replace the power supply if it doesn't work well;</p> <p>(4) Eliminate disturbance source;</p> <p>(5) Replace the circuit;</p> <p>(6) Remove all the other electrical equipment and metal articles (shelf, bag cabinet) in 2 meters around the antenna;</p> <p>(7) Adjust anticlockwise to decrease the sensitivity of the receiver while tune R14 clockwise to increase the sweep amplitude of the transmitter.</p>
Low alarm sensitivity	<p>(1) Make sure the tags are proper ones;</p> <p>(2) Check that whether there is metal object (shelves, trolleys) around the antenna.</p>	<p>(1) Redo the tuning according to the tuning manual to improve the sensitivity;</p> <p>(2) Change a new tag;</p> <p>(3) Eliminate the disturbing source.</p>